

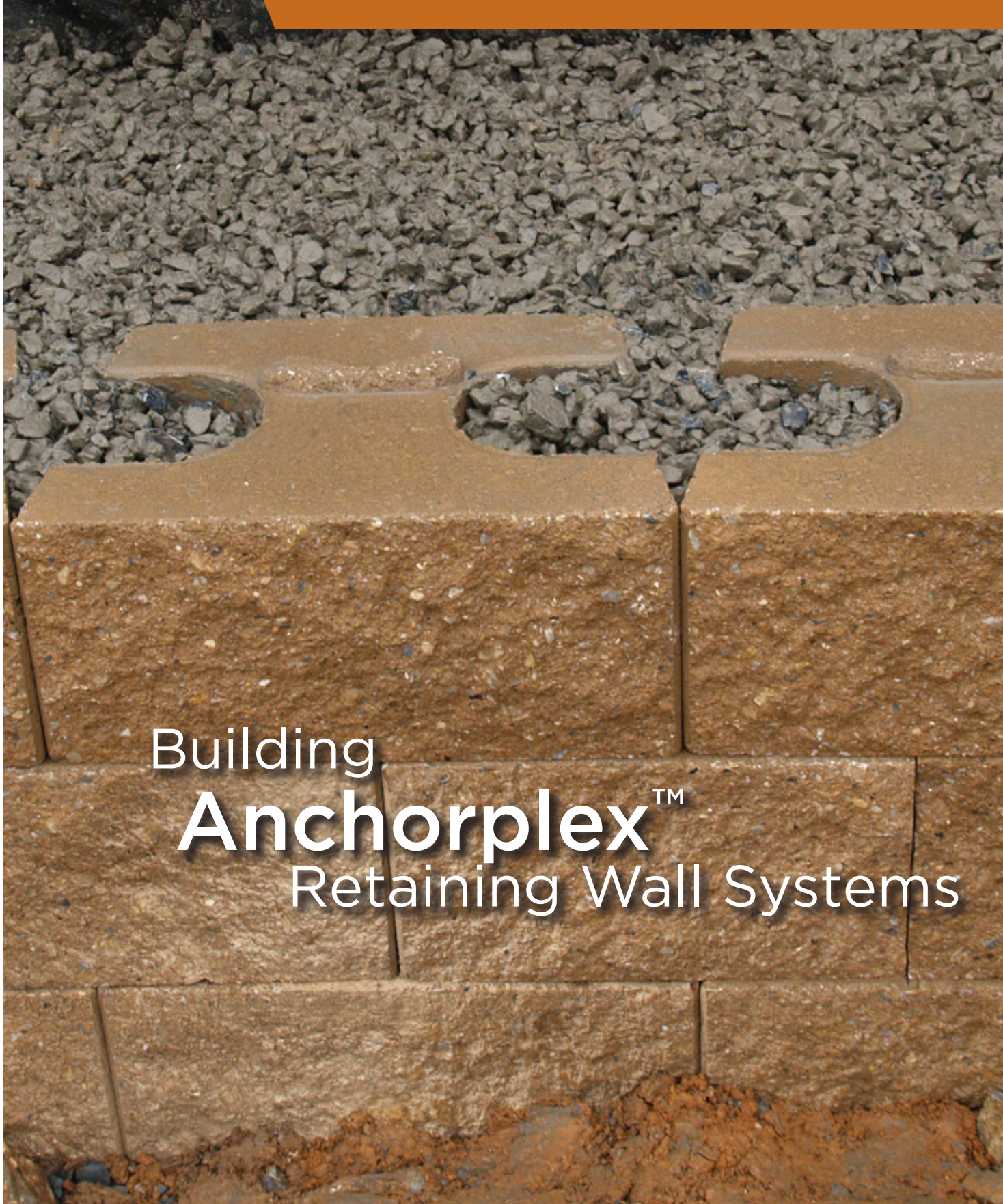

ANCHOR[®]
BUILD SOMETHING BEAUTIFUL



Building
Anchorplex[™]
Retaining Wall Systems

Table of Contents and Introduction

TABLE OF CONTENTS

How to Use This Guide	2
About the Anchorplex™ System	2
Anchorplex System Material Specifications	3
Anchorplex System Material Quantity Estimating	3
Anchorplex System Construction Basics	4
Construction Details for the Anchorplex System	6
Material Estimating Charts for Structural Backfill	9

HOW TO USE THIS GUIDE

Use this *Construction Guide* to gain a general understanding of the basics of building Anchorplex™ retaining walls.

Do not use this *Construction Guide* in lieu of construction drawings provided by a qualified engineer.

Contact Anchor Wall Systems at 1-877-295-5415 for more information about designing and building Anchorplex retaining wall systems.

ABOUT THE ANCHORPLEX™ SYSTEM

The Anchorplex system is a retaining wall built with Anchor™ products and self-compacting structural backfill that meets Anchor Wall Systems, Inc.'s specifications, and that is backed by engineering support tools developed by Anchor Wall Systems. Structural backfill, also known as “no-fines” concrete, is a widely available, easily workable, highly porous mixture of clean stone, cement and water. In the mid-1990s, Anchor’s licensee in Australia, Pioneer Building Products Ltd., developed a system of building retaining walls up to about 5 meters (about 15 feet) high from Anchor retaining wall blocks reinforced with a zone of structural backfill placed immediately behind the block facing.

When used in combination with blocks of the appropriate shape, the structural backfill attaches itself to the wall facing, effectively extending the depth and mass of the facing. In addition, the structural backfill zone also serves as the required drainage zone.

The Anchorplex construction method completely eliminates the need for the construction of a mechanically stabilized earth zone behind the wall facing and requires substantially less excavation and compaction than is usually necessary in a grid-reinforced wall construction project.

Because of these efficiencies and the design flexibility afforded with Anchorplex construction, millions of square feet of Anchorplex retaining walls have been installed and are performing well in Australia. Anchor Wall Systems is now introducing this construction method in North America and other parts of the world.

APPLICATIONS

Reinforced Walls Up to 10 Feet

Anchorplex construction is often a more cost-effective solution than building with geogrid reinforcement in walls up to about 10 feet tall.

Limited Room to Excavate

It is often possible to build an Anchorplex wall in situations where traditional geogrid reinforcement is not an option because of lot lines, rock outcroppings or other obstructions that limit the amount of excavation that can be done.

Competing with Machine-Placed “Big Blocks”

For wall heights less than 11 feet, Anchorplex walls are almost always more economical than machine-placed “big block” walls – and are always better-looking structures.



The structural backfill that meets Anchor Wall Systems, Inc.'s specifications allows water to drain behind the wall.

ANCHORPLEX™ SYSTEM MATERIAL SPECIFICATIONS

Structural Backfill Component

This component is made by mixing cementitious material, coarse aggregate and water. The cementitious material should be hydraulic cement (ASTM C 150 or C 1157), fly ash (ASTM C 618) or slag (ASTM C 989). The stone should be coarse aggregate, size number 6, 8 or 57, type 3S (ASTM C 33). Stone size selection should be based on the application. Generally, a block with a large core or one with large voids between it and adjacent blocks can more easily accept a mix design with larger aggregates. The water should be potable. The mixing ratios (by weight) of aggregate to cementitious material should be between 6:1 and 7:1. The mixing ratio (by weight) of water to cementitious material should be no more than 1:2. The resulting material, upon curing, should have at least 25% voids.

Facing-Block Component

The following Anchor™ retaining wall products can be used to build Anchorplex™ retaining walls:

- Vertica® products
- Vertica Pro® products
- Vertica Stone Cut® products
- Diamond Pro Stone Cut® products
- Diamond Pro® products
- Highland Stone® products
- Diamond Stone Cut® products
- Diamond® products

ANCHORPLEX SYSTEM MATERIAL QUANTITY ESTIMATING

Estimate the quantity of block needed on an Anchorplex job by conventional methods. Conventional block quantity estimating tools are available at www.anchorwall.com.

Estimate the quantity of Anchor-specified structural backfill material needed on an Anchorplex job using the Anchorplex Estimating Chart for Structural Backfill for the particular Anchor wall block system that you are using on the job. Each Anchorplex Estimating Chart for Structural Backfill is based upon Anchor's proprietary design methodology and is available for downloading at www.anchorwall.com.

The Anchorplex Estimating Charts for Structural Backfill for the Vertica wall system are included in this *Construction Guide* for illustrative purposes.



Too little water



Proper amount of water

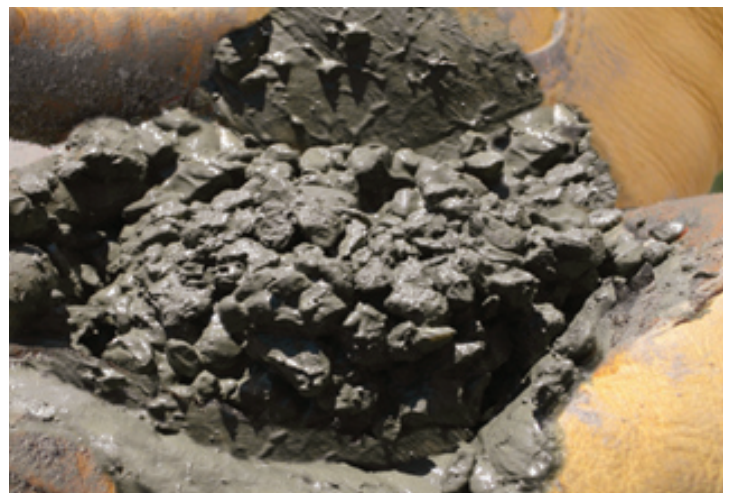

Too much water



1. SETTING OUT THE WALL AND EXCAVATION

This step is no different for Anchorplex™ system construction than for conventional construction, except that the amount of excavation will probably differ. Verify wall layout and wall location with the client and other appropriate parties. Survey grade stakes with distance to wall face, elevation for bottom of wall and steps in the foundation should be marked.

Mark the location of the excavation trench so that, when dug, it is wide enough to accommodate the wall block and leveling pad and complies with drawings and specifications. See Excavation Detail on page 6.

A geotechnical engineer should evaluate the foundation soil to verify that there is adequate bearing capacity for support of the structure before placing aggregate in the trench.

Firmly compact the soil in the base of the trench, using either a vibrating plate compactor or small vibrating trench roller before installing the leveling pad base aggregate.

2. LEVELING PAD

This step is no different for Anchorplex system construction than for conventional construction. Build the leveling pad from granular stone base material or $\frac{3}{4}$ -inch angular aggregate.

The pad must be a minimum of 6 inches deep after compaction. An additional distance of at least 6 inches in front of and behind the wall block must be included in the leveling pad. See Excavation Detail on page 6.

Fully compact the leveling pad using a vibrating plate compactor. Make sure the base material is level front to back and side to side.



3. BASE COURSE

This step is no different for Anchorplex construction than for conventional construction. It is the most important step in the construction process. Starting at the lowest point, lay the first block, checking level both front to back and side to side.

Place additional blocks side by side, flush against each other at the face, making sure the blocks are in full contact with the leveling pad.

Use a string line along back of blocks to align the wall units. Use a 4- to-6-foot level along the top of foundation blocks to check the level side to side and use a shorter level to check the level from front to back.

4. CONSTRUCTION OF ADDITIONAL COURSES

This step is no different for Anchorplex system construction than for conventional construction. Clean any debris off the top of blocks. Place the second course of blocks on top of the base course. Maintain running bond by placing units in a staggered pattern, running bond, to the course beneath. Pull each unit forward until the shear device is securely in contact with the units below. Use string line on each course to align the blocks along the wall. Do not exceed 2 feet vertical stacking of block before placing a lift of structural backfill.



5. DRAINAGE DESIGN

This step is no different for Anchorplex™ system construction than for conventional construction. The ground levels on a site will determine at what level to install the perforated drainpipe, but generally the drainpipe is positioned as low as possible behind the wall so water drains down, out and away from the wall into a storm drain or to an area lower than and away from the wall.



The perforated pipe should be placed approximately 6 inches behind the back of the block. The actual location of the drainpipe should be noted on the engineered shop drawings.

6. INSTALLATION OF STRUCTURAL BACKFILL

After completion of the leveling pad, base course, drainpipe installation and stacking block 2 feet above grade, the first lift of structural backfill that meets Anchor Wall Systems, Inc.'s specifications can be installed.

The structural backfill can be placed directly from delivery vehicle or with skid-type loader or other equipment. It should be placed behind the blocks and worked into all voids and cores of the blocks. When properly formulated, the structural backfill material will not leak through the face of the wall.

After installation of the first lift of structural backfill, install additional courses and repeat the process. Place additional lifts from 8 to 24 inches depending on site conditions and project scale. Subsequent pours can be made as soon as the structural backfill in the previous lift has set – usually not longer than 2 to 3 hours.

7. CAPPING

Follow standard practice when capping the wall.

8. FINISHING

Protect the wall with a finish grade at the top and bottom.



Construction Details for the Anchorplex™ System

TYPICAL BASE PREPARATION

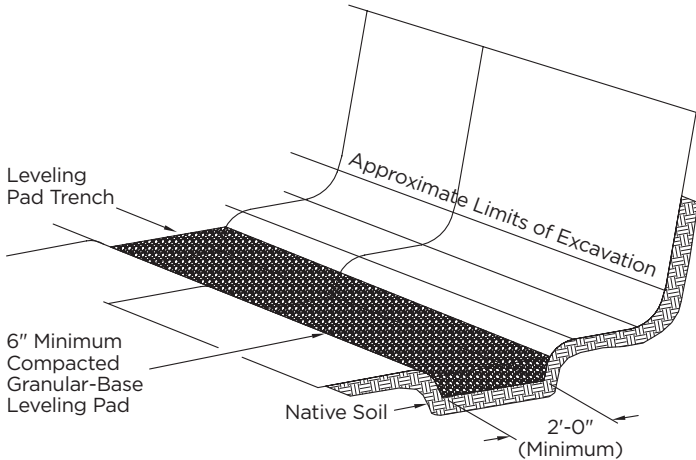

Construction Details show the use of Vertica® products. Details for other Anchor™ products are located at www.anchorwall.com.

1:1 EXCAVATION DETAIL

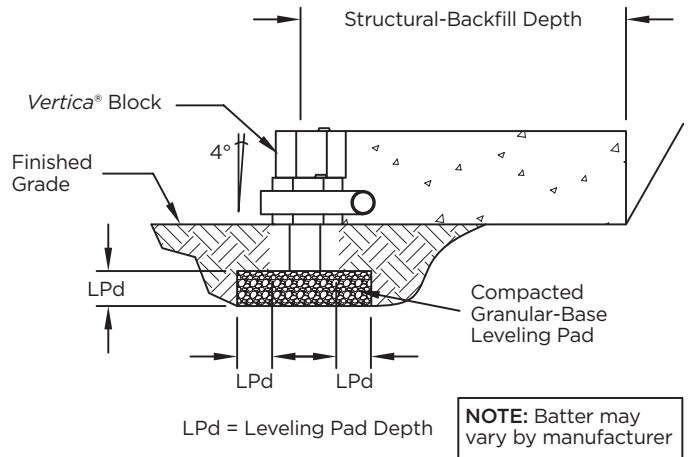

READY FOR FIRST POUR

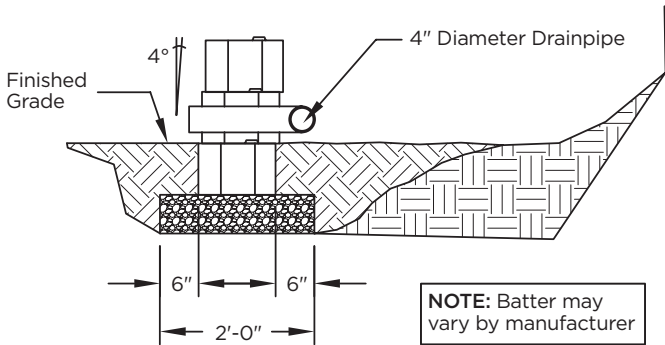

FIRST POUR

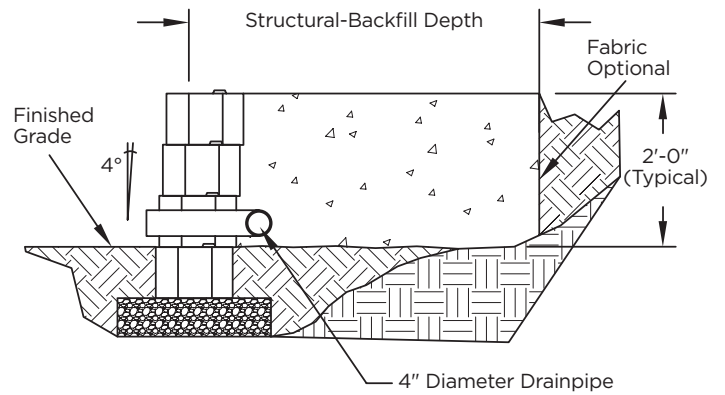

NOTES:

1. Structural backfill is to be placed in 8- to 24-inch (typical) lifts.
2. Structural backfill must be manipulated into all voids between blocks to ensure adequate bond between block and concrete mass.

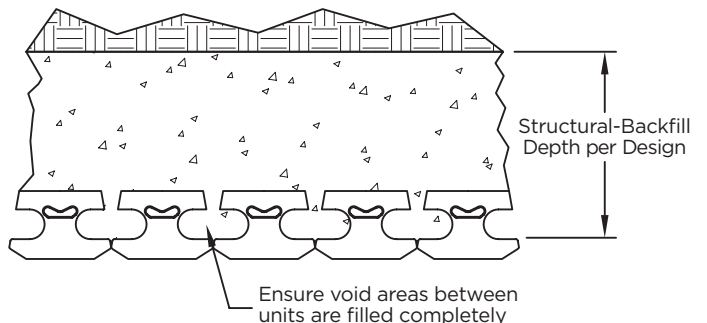

Construction Details for the Anchorplex™ System

Construction Details show the use of Vertica® products. Details for other Anchor™ products are located at www.anchorwall.com.

SUBSEQUENT POURS VERTICA® PRODUCTS

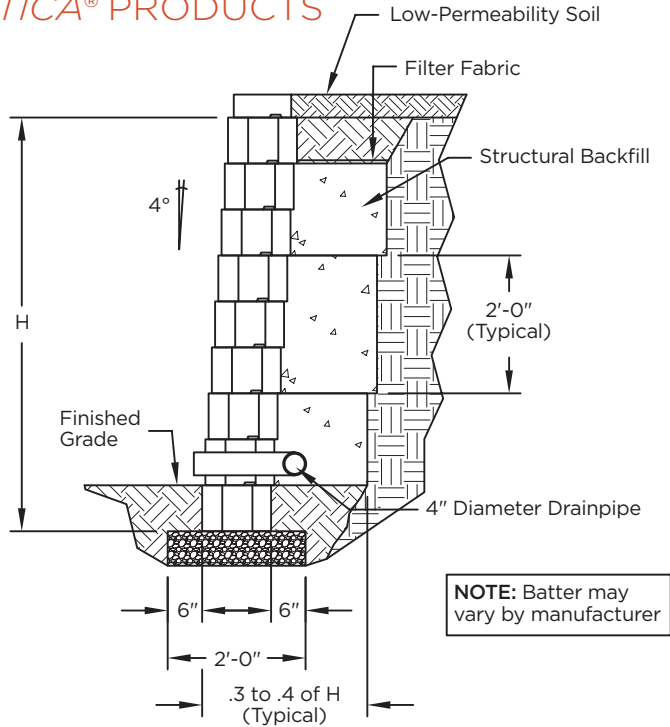

DAYLIGHT DETAILS

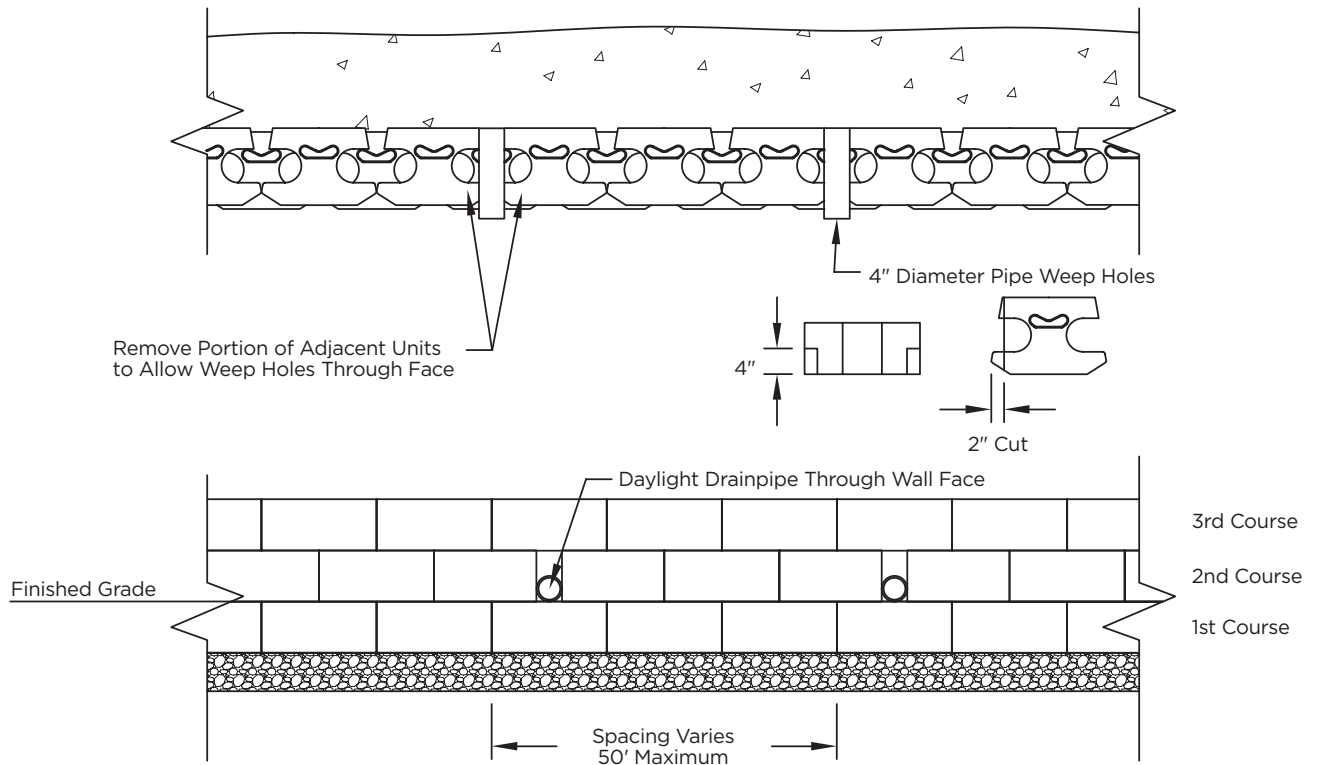

Construction Details for the Anchorplex™ System

Construction Details show the use of Vertica® products. Details for other Anchor™ products are located at www.anchorwall.com.

FENCE DETAILS

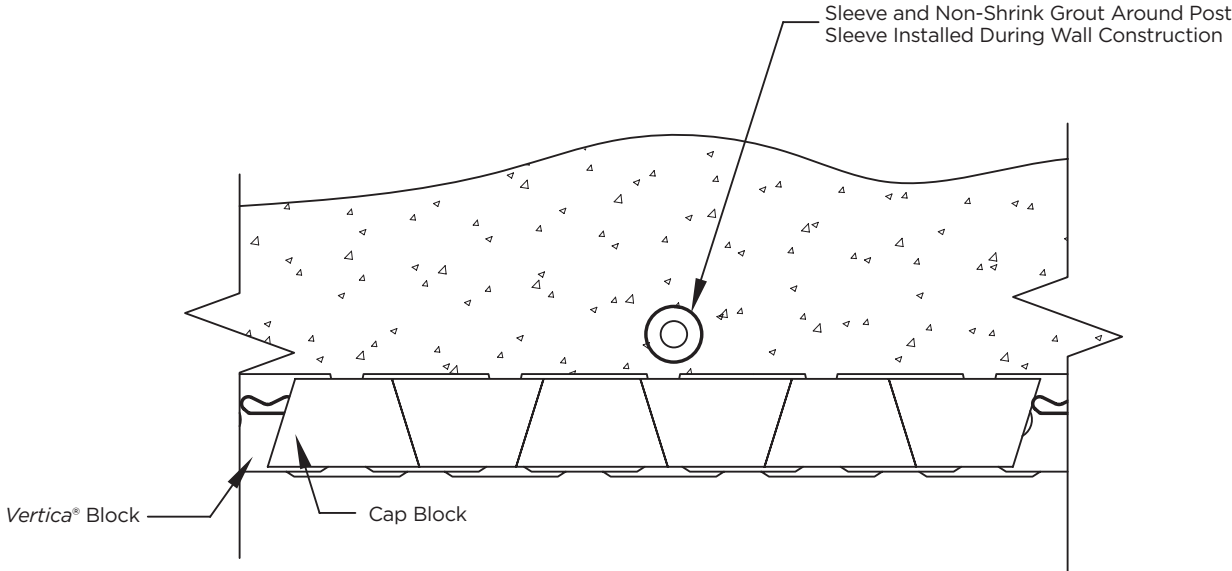
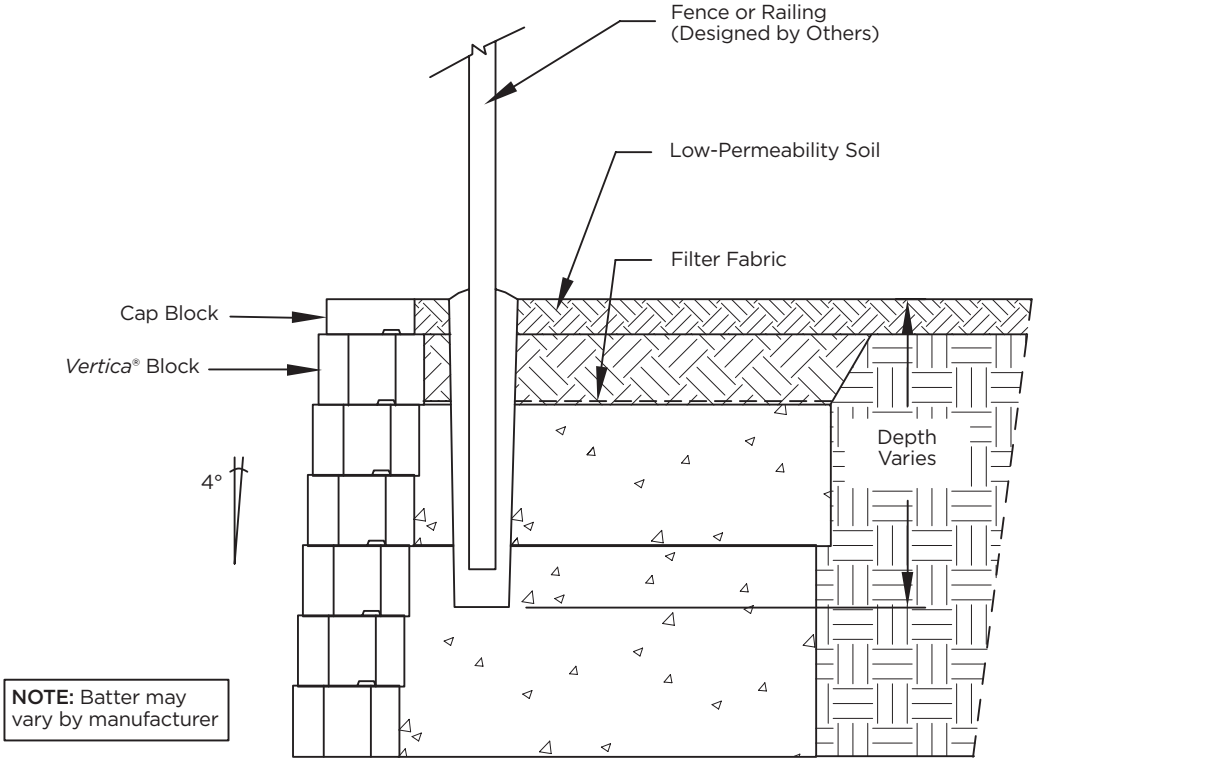

Material Estimating Charts for Structural Backfill

NO SLOPE OR SURCHARGE

Estimating Charts show the use of Vertica® products. Estimating Charts for other Anchor™ products are located at www.anchorwall.com.

CLAY AND SILT SOIL $\phi = 26^\circ$ $\gamma = 120 \text{ pcf (19 kN/m}^3\text{)}$	SILTY/CLAYEY SAND SOIL $\phi = 30^\circ$ $\gamma = 120 \text{ pcf (19 kN/m}^3\text{)}$	CLEAN SAND AND GRAVEL SOIL $\phi = 34^\circ$ $\gamma = 120 \text{ pcf (19 kN/m}^3\text{)}$
<p>NO SLOPE OR SURCHARGE</p> <p>ZONE OF STRUCTURAL BACKFILL</p>	<p>NO SLOPE OR SURCHARGE</p> <p>ZONE OF STRUCTURAL BACKFILL</p>	<p>NO SLOPE OR SURCHARGE</p> <p>ZONE OF STRUCTURAL BACKFILL</p>
<p>4 Courses 2'-8" (800mm)</p> <p>1'-0" [300mm]</p> <p>0.13 x Wall Length = CY of Structural Backfill</p>	<p>4 Courses 2'-8" (800mm)</p> <p>1'-0" [300mm]</p> <p>0.13 x Wall Length = CY of Structural Backfill</p>	<p>4 Courses 2'-8" (800mm)</p> <p>STRUCTURAL BACKFILL NOT REQUIRED</p>
<p>6 Courses 4'-0" (1200mm)</p> <p>1'-0" [300mm]</p> <p>0.19 x Wall Length = CY of Structural Backfill</p>	<p>6 Courses 4'-0" (1200mm)</p> <p>1'-0" [300mm]</p> <p>0.19 x Wall Length = CY of Structural Backfill</p>	<p>6 Courses 4'-0" (1200mm)</p> <p>1'-0" [300mm]</p> <p>0.19 x Wall Length = CY of Structural Backfill</p>
<p>8 Courses 5'-4" (1600mm)</p> <p>1'-7" [475mm]</p> <p>0.37 x Wall Length = CY of Structural Backfill</p>	<p>8 Courses 5'-4" (1600mm)</p> <p>1'-4" [400mm]</p> <p>0.32 x Wall Length = CY of Structural Backfill</p>	<p>8 Courses 5'-4" (1600mm)</p> <p>1'-0" [300mm]</p> <p>0.25 x Wall Length = CY of Structural Backfill</p>
<p>10 Courses 6'-8" (2000mm)</p> <p>2'-0" [600mm]</p> <p>0.56 x Wall Length = CY of Structural Backfill</p>	<p>10 Courses 6'-8" (2000mm)</p> <p>2'-0" [600mm]</p> <p>0.56 x Wall Length = CY of Structural Backfill</p>	<p>10 Courses 6'-8" (2000mm)</p> <p>1'-7" [475mm]</p> <p>0.46 x Wall Length = CY of Structural Backfill</p>
<p>12 Courses 8'-0" (2400mm)</p> <p>2'-7" [775mm]</p> <p>0.84 x Wall Length = CY of Structural Backfill</p>	<p>12 Courses 8'-0" (2400mm)</p> <p>2'-4" [700mm]</p> <p>0.77 x Wall Length = CY of Structural Backfill</p>	<p>12 Courses 8'-0" (2400mm)</p> <p>2'-0" [600mm]</p> <p>0.62 x Wall Length = CY of Structural Backfill</p>

Detail shown is conceptual only and should not be used for construction without the seal of a local qualified engineer.

Material Estimating Charts for Structural Backfill

250 PSF SURCHARGE

Estimating Charts show the use of Vertica® products. Estimating Charts for other Anchor™ products are located at www.anchorwall.com.

CLAY AND SILT SOIL $\phi = 26^\circ$ $\gamma = 120 \text{ pcf (19 kN/m}^3\text{)}$	SILTY/CLAYEY SAND SOIL $\phi = 30^\circ$ $\gamma = 120 \text{ pcf (19 kN/m}^3\text{)}$	CLEAN SAND AND GRAVEL SOIL $\phi = 34^\circ$ $\gamma = 120 \text{ pcf (19 kN/m}^3\text{)}$
<p>250 PSF (5 kPa) SURCHARGE</p> <p>ZONE OF STRUCTURAL BACKFILL</p>	<p>250 PSF (5 kPa) SURCHARGE</p> <p>ZONE OF STRUCTURAL BACKFILL</p>	<p>250 PSF (5 kPa) SURCHARGE</p> <p>ZONE OF STRUCTURAL BACKFILL</p>
<p>4 Courses 2'-8" (800mm)</p> <p>1'-4" [400mm]</p> <p>0.16 x Wall Length = CY of Structural Backfill</p>	<p>4 Courses 2'-8" (800mm)</p> <p>1'-4" [400mm]</p> <p>0.16 x Wall Length = CY of Structural Backfill</p>	<p>4 Courses 2'-8" (800mm)</p> <p>1'-0" [300mm]</p> <p>0.13 x Wall Length = CY of Structural Backfill</p>
<p>6 Courses 4'-0" (1200mm)</p> <p>2'-0" [600mm]</p> <p>0.34 x Wall Length = CY of Structural Backfill</p>	<p>4 Courses 2'-8" (800mm)</p> <p>2'-0" [600mm]</p> <p>0.34 x Wall Length = CY of Structural Backfill</p>	<p>6 Courses 4'-0" (1200mm)</p> <p>1'-7" [475mm]</p> <p>0.27 x Wall Length = CY of Structural Backfill</p>
<p>8 Courses 5'-4" (1600mm)</p> <p>2'-7" [775mm]</p> <p>0.56 x Wall Length = CY of Structural Backfill</p>	<p>8 Courses 5'-4" (1600mm)</p> <p>2'-4" [700mm]</p> <p>0.51 x Wall Length = CY of Structural Backfill</p>	<p>8 Courses 5'-4" (1600mm)</p> <p>2'-0" [600mm]</p> <p>0.45 x Wall Length = CY of Structural Backfill</p>
<p>10 Courses 6'-8" (2000mm)</p> <p>3'-4" [1000mm]</p> <p>0.89 x Wall Length = CY of Structural Backfill</p>	<p>10 Courses 6'-8" (2000mm)</p> <p>3'-0" [900mm]</p> <p>0.81 x Wall Length = CY of Structural Backfill</p>	<p>10 Courses 6'-8" (2000mm)</p> <p>2'-7" [775mm]</p> <p>0.70 x Wall Length = CY of Structural Backfill</p>
<p>12 Courses 8'-0" (2400mm)</p> <p>3'-11" [1175mm]</p> <p>1.24 x Wall Length = CY of Structural Backfill</p>	<p>12 Courses 8'-0" (2400mm)</p> <p>3'-7" [1075mm]</p> <p>1.14 x Wall Length = CY of Structural Backfill</p>	<p>12 Courses 8'-0" (2400mm)</p> <p>3'-0" [900mm]</p> <p>0.97 x Wall Length = CY of Structural Backfill</p>

Detail shown is conceptual only and should not be used for construction without the seal of a local qualified engineer.

Material Estimating Charts for Structural Backfill

3:1 CREST SLOPE

Estimating Charts show the use of Vertica® products. Estimating Charts for other Anchor™ products are located at www.anchorwall.com.

CLAY AND SILT SOIL $\phi = 26^\circ$ $\gamma = 120 \text{ pcf } (19 \text{ kN/m}^3)$	SILTY/CLAYEY SAND SOIL $\phi = 30^\circ$ $\gamma = 120 \text{ pcf } (19 \text{ kN/m}^3)$	CLEAN SAND AND GRAVEL SOIL $\phi = 34^\circ$ $\gamma = 120 \text{ pcf } (19 \text{ kN/m}^3)$
<p>4 Courses 2'-8" (800mm)</p> <p>1'-0" [300mm]</p> <p>0.13 x Wall Length = CY of Structural Backfill</p>	<p>4 Courses 2'-8" (800mm)</p> <p>1'-0" [300mm]</p> <p>0.13 x Wall Length = CY of Structural Backfill</p>	<p>4 Courses 2'-8" (800mm)</p> <p>1'-0" [300mm]</p> <p>0.13 x Wall Length = CY of Structural Backfill</p>
<p>6 Courses 4'-0" (1200mm)</p> <p>1'-5" [425mm]</p> <p>0.25 x Wall Length = CY of Structural Backfill</p>	<p>6 Courses 4'-0" (1200mm)</p> <p>1'-0" [300mm]</p> <p>0.19 x Wall Length = CY of Structural Backfill</p>	<p>6 Courses 4'-0" (1200mm)</p> <p>1'-0" [300mm]</p> <p>0.19 x Wall Length = CY of Structural Backfill</p>
<p>8 Courses 5'-4" (1600mm)</p> <p>2'-0" [600mm]</p> <p>0.45 x Wall Length = CY of Structural Backfill</p>	<p>8 Courses 5'-4" (1600mm)</p> <p>1'-7" [475mm]</p> <p>0.37 x Wall Length = CY of Structural Backfill</p>	<p>8 Courses 5'-4" (1600mm)</p> <p>1'-4" [400mm]</p> <p>0.32 x Wall Length = CY of Structural Backfill</p>
<p>10 Courses 6'-8" (2000mm)</p> <p>2'-7" [775mm]</p> <p>0.70 x Wall Length = CY of Structural Backfill</p>	<p>10 Courses 6'-8" (2000mm)</p> <p>2'-0" [600mm]</p> <p>0.56 x Wall Length = CY of Structural Backfill</p>	<p>10 Courses 6'-8" (2000mm)</p> <p>2'-0" [600mm]</p> <p>0.56 x Wall Length = CY of Structural Backfill</p>
<p>12 Courses 8'-0" (2400mm)</p> <p>3'-4" [1000mm]</p> <p>1.07 x Wall Length = CY of Structural Backfill</p>	<p>12 Courses 8'-0" (2400mm)</p> <p>2'-4" [700mm]</p> <p>0.77 x Wall Length = CY of Structural Backfill</p>	<p>12 Courses 8'-0" (2400mm)</p> <p>2'-4" [700mm]</p> <p>0.77 x Wall Length = CY of Structural Backfill</p>

Detail shown is conceptual only and should not be used for construction without the seal of a local qualified engineer.

Anchorplex™ Retaining Wall Construction Guide



© 2012 Anchor Wall Systems, Inc. The Diamond®, Diamond Pro®, Diamond Pro Stone Cut®, Diamond Stone Cut®, Highland Stone®, Vertica®, Vertica Pro® and Vertica Stone Cut® wall systems are manufactured under license from Anchor Wall Systems, Inc. (AWS). The “Anchor A” and “Anchor Build Something Beautiful” logos, “Anchor,” “Anchorplex,” “Diamond,” “Diamond Pro,” “Diamond Pro Stone Cut,” “Diamond Stone Cut,” “Highland Stone,” “Vertica,” “Vertica Pro” and “Vertica Stone Cut” are trademarks of AWS. The wall system blocks are covered by the AWS Limited Warranty. For a complete copy, visit your local dealer or see anchorwall.com.

Anchor Wall Systems, Inc., 5959 Baker Road, Suite 390, Minnetonka, MN 55345.
A&B1001

73.3377.1 02/12 4027