

Sonneborn®**Waterproofing
Systems****SONOSHIELD®****SONOGUARD®****Polyurethane waterproof coating systems for
vehicular and pedestrian traffic areas****Where to Use
Sonoguard®**

- Concrete
- Exterior-grade plywood
- Stadiums
- Balconies
- Parking ramps
- Mechanical rooms
- Plazas

**Sonoguard® coating
systems are
composed of:**

- Sonoguard® Base Coat—
one-component mois-
ture-curing polyurethane
- Sonoguard® Top Coat—
one-component aliphatic
moisture-curing
polyurethane
- Sonoguard® Top Coat
Tint Base—consists of
40 standard colors, (refer
to Form No. 1017936)

For projects requiring
primer, two choices are
available:

- Primer 772 VOC—a sin-
gle-component solvent-
based primer and sealer
- Primer 770—a two-
component waterborne
epoxy primer and sealer

Features

- No primer coat required...
- VOC compliant...
- Waterproof...
- Protects from chloride intrusion...
- Skid resistant...
- Multiple systems available...
- Seamless elastomeric membrane...
- Repairable and recoatable...

Benefits

- Lower labor and material costs
- Environmentally responsible
- Protects concrete from freeze-thaw damage
- Protects occupied areas below from water damage
- Extends life of reinforcing steel
- Increased safety
- Ideal for vehicular or heavy pedestrian traffic
- No seams to cause leaks
- Extends the useful life of the system

How to Apply Sonoguard®

Surface Preparation Concrete

1 Concrete must be fully cured (28 days), structurally sound, clean and dry. All concrete surfaces (new and old) must be mechanically prepared to remove previous coatings, laitance, and all miscellaneous surface contamination and to provide profile for proper adhesion.

2 Patch voids and delaminated areas with Sonocrete® patching materials.

3 For nonmoving joints and cracks less than 1/16" (1.6 mm) wide, apply primer when required, followed by 25 wet mils (0.6 mm) prestripping of Base Coat. The Base Coat must be applied to fill and overlap the joint or crack 3" (76 mm) on each side. Feather the edges.

4 Dynamic cracks and joints over 1/16" (1.6 mm) wide must be routed to a minimum of 1/4" by 1/4" (6 mm by 6 mm) and cleaned. Install bondbreaker tape to prevent adhesion of sealants to the bottom of joint. Prime joint faces only with Sonneborn Primer 733 (refer to Form No. 1017962). Fill joints deeper than 1/4" (6 mm) with appropriate backer-rod and SL 2™ (slope grade or self-leveling) or Ultra sealants (refer to Form Nos. 1017903 and 1017894).

5 Sealed joints 1" (25 mm) or less can be coated over with Sonoguard®. Expansion joints exceeding 1" (25 mm) wide should not be coated over with Sonoguard® so they can perform independently of the deck coating system.

6 Cut a 1/4" by 1/4" (6mm by 6mm) keyway into the concrete where the coating system will be terminated and no wall, joint, or other appropriate break exists. Fill according to instructions on cracks and joints over 1/16" (1.6 mm) wide.

7 Form a sealant cant into the corner at the junction of all horizontal and vertical surfaces (wall sections,



Roller cover application of the intermediate coat.

curbs, columns). Prime with Primer 733 and apply a 1/2" to 1" (13 to 25 mm) wide bead of NP 1™, NP 2™ or Ultra sealants. Tool to form a 45° cant.

8 In locations of potential high movement, such as wall and slab intersections, apply 25 wet mils (0.6 mm) of Sonoguard® Base Coat and embed Sonoshield® Reinforcing Fabric.

Metal Surfaces

Remove dust, debris, and any other contaminants from vent, drain-pipe, and post penetrations; reglets; and other metal surfaces. Clean these surfaces to bright metal and prime with Primer 733. Provide appropriate cant with NP 1™, NP 2™ or Ultra sealant to eliminate 90° angles.

Plywood

1 All plywood must be smooth-faced, APA-stamped, and exterior grade. Construction must conform to code, but plywood must not be less than 15/32" (12 mm) thick. Plywood spacing and deck construction must follow APA guidelines.

2 Surfaces must be free of contaminants. Priming is not necessary on clean, dry plywood.

3 All seams must be caulked with NP 1™, NP 2™ or Ultra sealants (refer to Form Nos. 1017906, 1017911 and 1017894). Prestripe 4 -

6" (102 - 152 mm) wide with 25 wet mils (0.6 mm) of slope-grade base coat. Reinforce all seams between plywood sheets and between flashing and the plywood deck by embedding Sonoshield® Reinforcing Fabric into the prestripping.

Application

1 All preparatory work must be completed before application begins. Be certain the substrate is clean, dry, stable and properly profiled. Sealants and prestripping should be properly cured. The base, mid, and finish coats are applied with a properly sized squeegee to arrive at the required mil thicknesses. (Airless spray equipment may also be used.)

The best method to ensure the proper wet film thickness is the use of a grid system. Divide the surface to be coated into grids and calculate the square footage of each. Refer to the coverage chart to determine the quantity of Sonoguard® needed for each grid to arrive at the required mil thicknesses.

For example, one pail of Sonoguard® will cover an area approximately 300 sq. ft. (28 m²), or a grid 30' x 10' (9 x 3 m) at 25 wet mils (0.6 mm).

The mil thickness of all coats can also be verified by the use of a wet-mil thickness gauge.

Note: When primer is required on a job, follow No. 2 and 3. When applying Sonoguard® without using a primer, proceed to No. 4.

2 After thoroughly vacuuming the surface, apply Primer 772 VOC or Primer 770 to all the properly prepared deck surfaces at the rate of 200 - 250 sq. ft. (4.9 - 6.1 m²/L) per gallon. Using a roller pan and a short- to medium-nap roller cover, force the primer into pores and voids to eliminate pinholes. Do not apply over prestripping. Use only solvent-resistant tools and equipment.

3 Allow primer to dry tack free. Base Coat must be applied the same working day.

4 Apply Base Coat 25 wet mils thick (0.6 mm) (using a notched squeegee) to entire deck surface, overcoating the properly prepared cracks, joints, and flashings. For sloped areas, use Slope-Grade Base Coat. Do not coat expansion joints over 1" (25 mm) wide.

5 Allow curing time of overnight (16 hour minimum). Slightly extend the curing time in cool or dry weather conditions. The surface of the base coat should have a slight tack. If the coating has been exposed for a prolonged period, consult Technical Services for recommendations.

Application Methods

Sonoguard® can be applied using several methods, depending on the degree of traffic the system is exposed to. The following summary briefly describes each method. All coverage rates are approximate.

PEDESTRIAN SYSTEM

Sonoguard® Top Coat (20 wet mils) with aggregate backrolled into wet top coat.

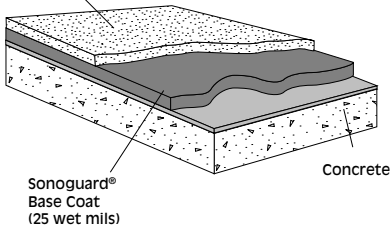

LIGHT TO MEDIUM DUTY TRAFFIC SYSTEM

Sonoguard® Top Coat (25 wet mils) with aggregate backrolled into wet top coat.

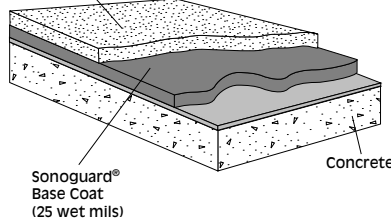

HEAVY DUTY TRAFFIC SYSTEM (Aggregate to Refusal Method)

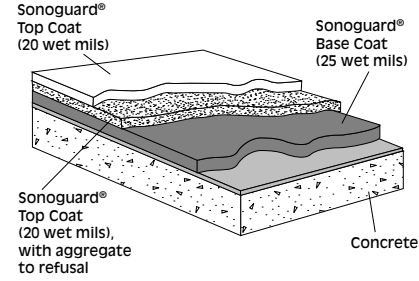

- 1 Prime concrete substrate (if required).
- 2 Apply 25 wet mils (0.6 mm) Sonoguard® Base Coat (using a notched squeegee) at 60 sq. ft. per gallon (1.5 m²/L). Immediately backroll to level Base Coat. Allow to cure overnight.
- 3 Apply 20 wet mils (0.5 mm) Sonoguard® Top Coat (using a notched squeegee) at 80 sq. ft. per gallon (2.0 m²/L). Immediately backroll to level Top Coat material. While the coating is still wet, broadcast Sonoguard® Aggregate or 16 - 30 rounded silica sand at 10 - 25 lbs. per 100 sq. ft. (0.5 - 1.25 kg/m²), then backroll into the coating.

- 1 Prime concrete substrate (if required).
- 2 Apply 25 wet mils (0.6 mm) Sonoguard® Base Coat (using a notched squeegee) at 60 sq. ft. per gallon (1.5 m²/L). Immediately backroll to level Base Coat. Allow to cure overnight.
- 3 Apply 25 wet mils (0.6 mm) Sonoguard® Top Coat (using a notched squeegee) at 60 sq. ft. per gallon (1.5 m²/L). Immediately backroll to level Top Coat material. While the coating is still wet, broadcast Sonoguard® Aggregate or 16-30 rounded silica sand at 10 - 25 lbs. per 100 sq. ft. (0.5 - 1.25 kg/m²), then backroll into the coating.

- 1 Prime concrete substrate (if required).
- 2 Apply 25 wet mils (0.6 mm) Sonoguard® Base Coat (using a notched squeegee) at 60 sq. ft. per gallon (1.5 m²/L). Immediately backroll to level Base Coat. Allow to cure overnight.
- 3 Apply 20 wet mils (0.5 mm) Sonoguard® Top Coat (using a notched squeegee) at 80 sq. ft. per gallon (2.0 m²/L). Immediately backroll to level Top Coat. While coating is still wet, broadcast Sonoguard® Aggregate or 16 - 30 rounded silica sand to refusal at approximately 50 - 60 lbs. per 100 sq. ft. (2.5 - 3 kg/m²). Allow to cure overnight.

HEAVY DUTY TRAFFIC SYSTEM (Aggregate Backroll Method)

Sonoguard® Top Coat (20 wet mils) with aggregate backrolled into wet top coat

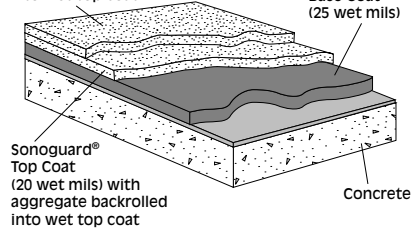

EXTRA HEAVY DUTY SYSTEM

Sonoguard® Top Coat (20 wet mils)

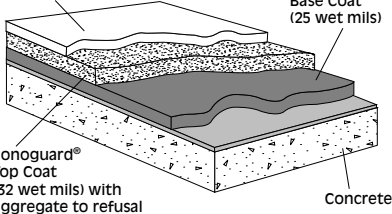

- 1 Prime concrete substrate (if required).
- 2 Apply 25 wet mils (0.6 mm) Sonoguard® Base Coat (using a notched squeegee) at 60 sq. ft. per gallon (1.5 m²/L). Immediately backroll to level Base Coat. Allow to cure overnight.
- 3 Apply 20 wet mils (0.5 mm) Sonoguard® Top Coat (using a notched squeegee) at 80 sq. ft. per gallon (2.0 m²/L). Immediately backroll to level Top Coat. While coating is still wet, broadcast Sonoguard® Aggregate or 16 - 30 rounded silica sand at 10 - 25 lbs. per 100 sq. ft. (0.5 - 1.25 kg/m²), then backroll into the coating. Allow to cure overnight.
- 4 Apply 20 wet mils (0.5 mm) Sonoguard® Top Coat (using a notched squeegee) at 80 sq. ft. per gallon (2.0 m²/L). Immediately backroll to evenly level Top Coat. While coating is still wet, broadcast Sonoguard® Aggregate or 16 - 30 rounded silica sand at 10 - 25 lbs. per 100 sq. ft. (0.5 - 1.25 kg/m²), then backroll into the coating.

- 1 Prime concrete substrate (if required).
- 2 Apply 25 wet mils (0.6 mm) Sonoguard® Base Coat (using a notched squeegee) at 60 sq. ft. per gallon (1.5 m²/L). Immediately backroll to level Base Coat. Allow to cure overnight.
- 3 Apply 32 wet mils (0.8 mm) Sonoguard® Top Coat (using a notched squeegee) at 50 sq. ft. per gallon (1.2 m²/L). Immediately backroll to level Top Coat. While the coating is still wet broadcast Sonoguard® Aggregate or 16 - 30 rounded silica sand to refusal at 60 - 80 lbs. per 100 sq. ft. 3 - 4 kg/m². Allow to cure overnight.

- 4 Remove all loose aggregate, then apply 20 wet mils (0.5 mm) Sonoguard® Top Coat (using a flat squeegee) at 80 sq. ft. per gallon (2.0 m²/L). Immediately backroll to evenly level Top Coat.

- 4 Remove all loose aggregate, then apply 20 mils (0.5 mm) Sonoguard® Top Coat (using a flat squeegee) at 80 sq. ft. per gallon (2.0 m²/L). Immediately backroll to level Top Coat.

Important Note

All coverage rates are approximate and may vary due to the application technique used. Actual coverage rate will depend on finish and porosity of the substrate.

Mockup:

Provide mockup of at least 100 sq. ft. (9.3 m²) to include surface profile, sealant joint, crack, flashing, and juncture details and allow for evaluation of slip resistance and appearance of Sonoguard® Systems.

- 1 Install mockup with specified coating types and with other components noted.
- 2 Locate where directed by architect.
- 3 Mockup may remain as part of work if acceptable to architect.

For recoat applications, see Sonoguard® Recoat System technical bulletin (Form No. 1018/128).

Curing Time

Allow curing time of 72 hours before vehicular use and 48 hours before pedestrian use. Extend the curing time in cool weather conditions. To reduce the timeframe in which Sonoguard® might be vulnerable to inclement

weather, or to reduce the time between coats, use Sonoguard® Top Coat Accelerator (See Form No. 1018139).

Maintenance

Surfaces may be cleaned with commercial detergents. Sonneborn recommends that a maintenance

agreement be established between the owner and applicator. Periodic inspection and repair of damaged surfaces will greatly prolong the performance and life of the system. Remove all sharp debris such as sand, gravel, and metal on a regular basis to avoid damage to the coating.

When removing snow, avoid the use of metal blades or buckets that may damage the coating.

Clean Up

Clean all tools and equipment with Reducer 990 or xylene.

For Best Performance

- Concrete should have a minimum compressive strength of 3,000 psi (20.7 MPa) and be cured for a minimum of 28 days.
- Ensure Sonoguard® system will not be subjected to rising water tables or hydrostatic pressure on slab-on-grade decks.
- Be sure to allow for movement in the deck by the proper design and use of expansion and control joints.
- When applying sealants, use backing materials according to industry standards.
- Be certain that all aggregate not properly encapsulated is thoroughly removed.
- When used interior provide adequate ventilation with a minimum of 6 air changes per hour.
- When adequate ventilation for use of Sonoguard® cannot be maintained, refer to technical data guide for Conipur II Deck Coating System (Form No. 1017917).
- Do not apply when substrates are over 90°F (32°C), under 40°F (4°C).
- On steep ramps in excess of 15%, profile surface and apply Penetrating Sealer 40 VOC.
- Sonoguard® Aggregate 16/30, rounded select silica sand is recommended.
- When applying to metal pan decks or decks containing between-slab membranes, contact Technical Service.
- Select the proper amount of aggregate to promote slip resistance.
- Prestripe to level out recessed sealant joints (less than 1" [25 mm]) for optimal aesthetic appearance.
- In areas of extreme traffic (turning lanes, pay booths, entrances and exits), apply the Extra Heavy-Duty Traffic System. Multiple coats with sand to rejection may be required; contact Technical Services for more information.
- Make certain the most current version of this data guide is being used; call Customer Service (1-800-433-9517) to verify the most current version.
- Proper application is the responsibility of the user. Field visits by ChemRex® personnel are for the purpose of making technical recommendations only and are not for supervising or providing quality control on the jobsite.

Avoid application of Sonoguard®

- when inclement weather is present or imminent
- to damp, wet, or contaminated surfaces
- where chained or metal-studded tires will be used

Troubleshooting

The following tips can be used to solve possible problems as well as avoid them.

1 Problem: Irregular appearance...Possible causes: substrate too rough, uneven coating application, uneven aggregate distribution.

Solution: Recoating may improve appearance. The number of additional coat(s) is dependent on the degree of irregularity. A sample recoat should be done.

2 Problem: Premature wear over high spots... Possible causes: failure to grind down abnormally rough concrete or junctions of slabs that do not line up evenly.

Solution: Grind high areas. Recoat affected area with entire Sonoguard® system.

3 Problem: Uneven aggregate distribution... Possible causes: casting aggregate into an uneven coating, not casting aggregate consistently.

Solution: Aggregate should be evenly distributed before encapsulation. If the surface cures unevenly, a recoat may improve appearance. Use a sample area to gauge results of recoat.

4 Problem: Inadequate slip resistance...Possible causes: inconsistent coating application, failure to properly embed aggregate, overly heavy finish coat.

Solution #1: When installing aggregate to refusal method, incorporate an additional 10 lb./100 ft.² (0.5 kg/m²) aggregate into the final lock coat

Solution #2: Start with a sample area. Lightly abrade surface to expose aggregate. Refer to Sonoguard® Recoat technical bulletin (Form No. 1018128).

Problem: Blisters...Possible causes: coating application too heavy or a wet substrate.

Solution: Cut blisters and spot repair as needed.

5 Problem: Poor adhesion to concrete...Possible causes: concrete surface too smooth (not properly profiled) or friable; concrete contaminated by dirt, oil, or moisture, etc.

Solution: Fix underlying problem, then reapply Sonoguard® system.

6 Problem: Intercoat adhesion is poor...Possible causes: preceding coat contaminated by dirt or moisture; topcoat applied past critical recoat time.

Solution: Fix underlying problem, then reapply Sonoguard® system. For additional information, contact Sonneborn Technical Services.

7 Problem: Sagging in vertical applications.

Solution: Apply multiple thin coats of both base and top coats to achieve desired film thickness. If puddling does occur, backroll as soon as possible.

Technical Data

Compliances

- UL 790 Class A Fire Rating
- ASTM C 957
- ASTM E 84

Test Data

Property*	Base Coat (self-leveling)	Top Coat (self-leveling)	Method
Weight per gallon, lbs.	9.9	9.1	ASTM D 1475
Specific gravity	1.19	1.09	
Solids by weight, %	84	77	ASTM D 1259
Solids by volume, %	81	75	
Viscosity, cps	4,000-9,000	2,000-4,000	ASTM D 2393
Flash Point, °F (°C)	104 (40)	105 (40.5)	ASTM D 56
*Uncured material			

Property	Base Coat	Top Coat	Method
Hardness, Shore A	60	89	ASTM D 2240
Tensile strength, psi (MPa)	752 (5.2)	2,500 (17.2)	ASTM D 412
Elongation, %	595	502	ASTM D 412
Tear strength, PIT	74	199	ASTM D 1004

Property	Requirements
ASTM C 957	
Abrasion resistance, mg lost (CS17 wheel 1000 g/1000 cycles)	1 mg (system passes) Max: 50

Property	Base Coat	Top Coat	Requirements
Crack bridging	System passes		ASTM 957 (1,000 cycles)
Weight loss, % Low Temperature Flexibility and Crack Bridging	16	17	Max: 40
Adhesion in peel after water immersion, pli primed mortar plywood	43 34	N/A N/A	5 5

Property (ASTM C 957)	Requirements
Elongation Recovery	System 94% Min: 90
Tensile Retention	System 151% Min: 80
Elongation Retention	System 94% Min: 90

Chemical	Base Coat	Top Coat	Requirements
Ethylene glycol	88	92	Min: 70
Mineral spirits	47	60	Min: 45
Water	96	83	Min: 70

Test results are averages obtained under laboratory conditions. Reasonable variations can be expected.

Order Information

Packaging

Primer 772 VOC

- 5 gallon (18.93 L) pails

Primer 770

- 4 gallon (15.14 L) units in 5 gallon pails (18.93 L)

Base Coat, (self-leveling and slope-grade):

- 5 gallon (18.93 L) pails
- 55 gallon (208 L) drums

Top Coat

- 5 gallon (18.93 L) pails
- 55 gallon (208 L) drums

Top Coat Accelerator

- 1 pint (473 mL) cans

Sonoguard® Adhesion Promoter (for recoat applications)

- 0.5 pint (236 mL) cans

Shelf life is typically 1 year when stored in unopened containers under normal conditions.

Colors



Gray



Charcoal Gray

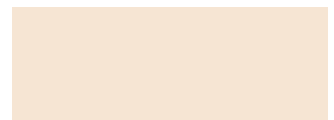

Tan

Colors are approximate; conduct final color matching with actual material.

For special colors, refer to Sonoguard® Top Coat Tint Base (Form No. 1017936).

Coverage

	Pedestrian	Light to Med Duty	Heavy Duty (refusal method)	Heavy Duty (backroll method)	Extra Heavy Duty
Base coat					
Wet mils (mm)	25 (0.6)	25 (0.6)	25 (0.6)	25 (0.6)	25 (0.6)
Dry mils (mm)	20 (0.5)	20 (0.5)	20 (0.5)	20 (0.5)	20 (0.5)
Coverage**	60 (1.5)	60 (1.5)	60 (1.5)	60 (1.5)	60 (1.5)
Mid coat					
Wet mils (mm)	None	None	20 (0.5)	20 (0.5)	32 (0.8)
Dry Milis (mm)	None	None	15 (0.4)	15 (0.4)	25 (0.6)
Coverage**	None	None	80 (2.0)	80 (2.0)	50 (1.2)
Finish coat					
Wet mils (mm)	20 (0.6)	25 (0.6)	20 (0.5)	20 (0.5)	20 (0.5)
Dry Milis (mm)	15 (0.4)	20 (0.5)	15 (0.4)	15 (0.4)	15 (0.4)
Coverage**	80 (2.0)	60 (1.5)	80 (2.0)	80 (2.0)	80 (2.0)
Aggregate*					
lbs. per 100 sq. ft. (kg/m ²)	10 - 25 (0.5 - 1.25)	10 - 25 (0.5 - 1.25)	50 - 60 (2.5 - 3.0)	10 - 25 (0.5 - 1.25) (2 applications)	60 - 80 (3.0 - 4.0)

Coverage rates are approximate, and may vary due to the application technique used. Actual coverage rate will also depend on finish and porosity of the substrate.

* (16 - 30 mesh rounded silica sand or proportional equivalent)

** Coverage is ft.²/gal. (m²/L)

Detail Drawings

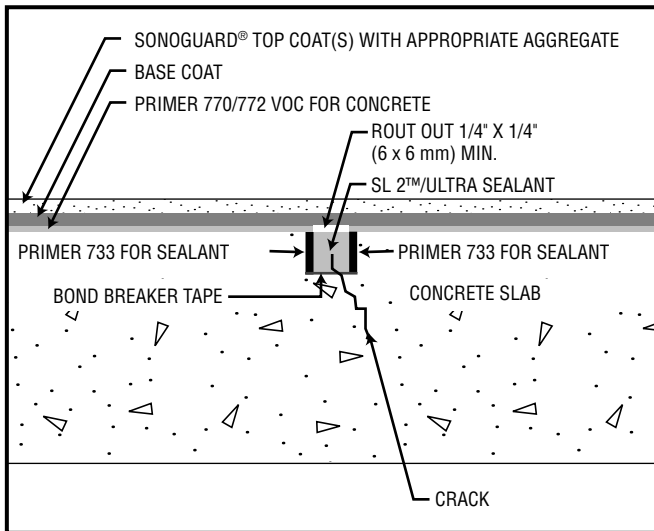

Crack Details (Dynamic)

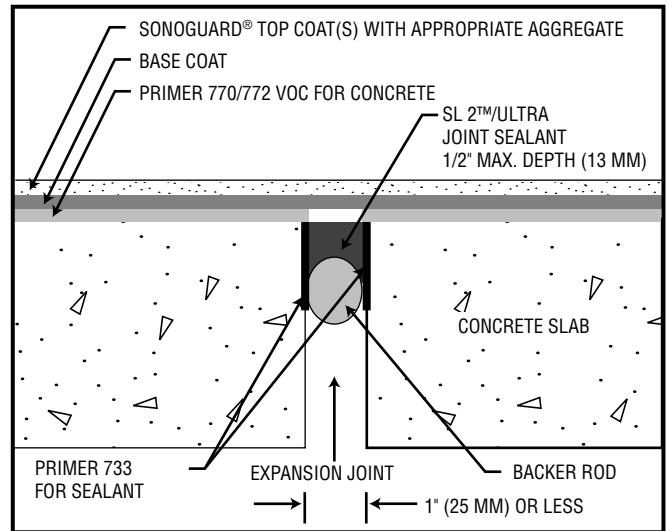

Expansion Joint Detail (Less Than 1")

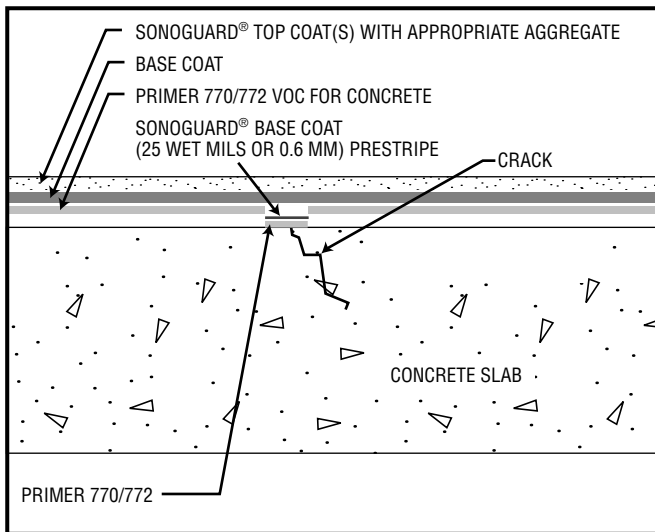

Crack Detail (Static) – Sporadic Cracking

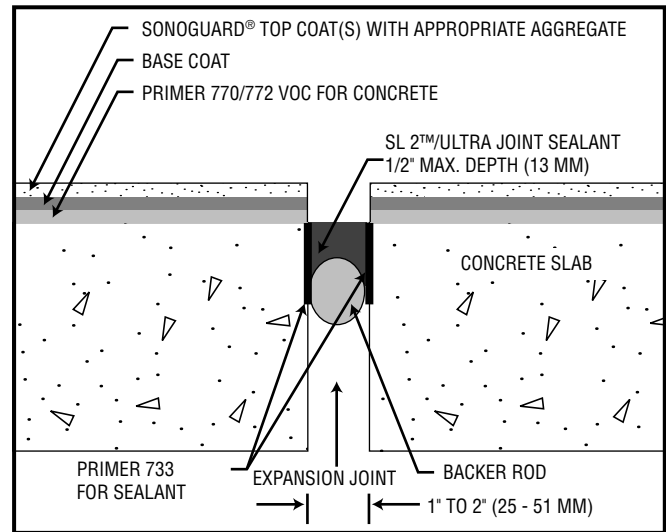

Expansion Joint Detail (Greater Than 1")

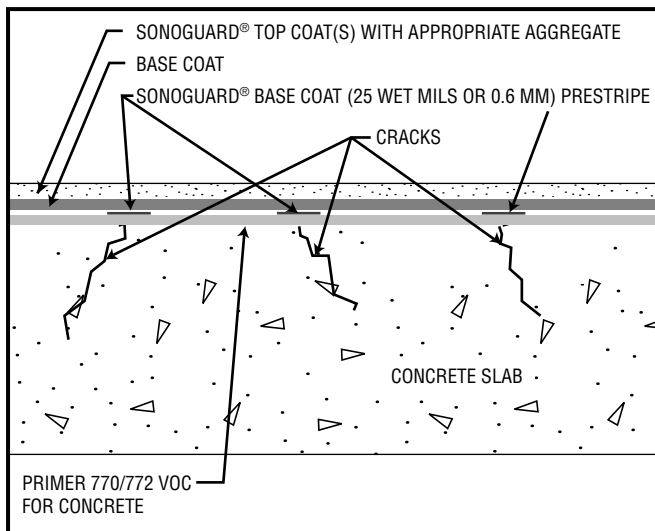

Crack Detail (Static) – Alternate Option for Widespread Cracking

General design details. Specific installations may require designer modification

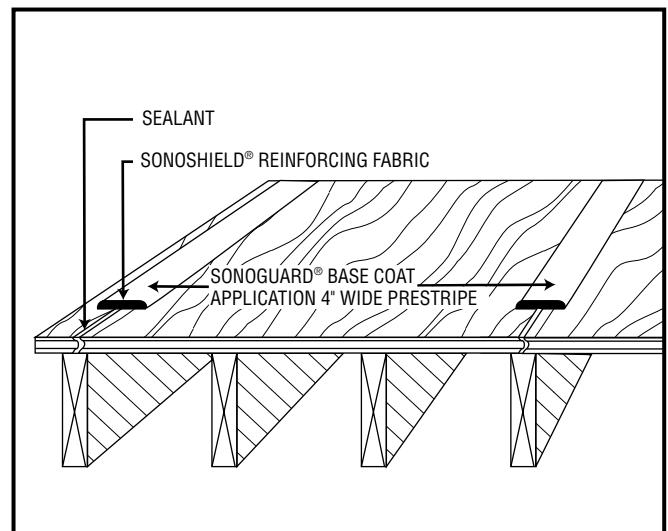

Plywood Application (Seam Detail)

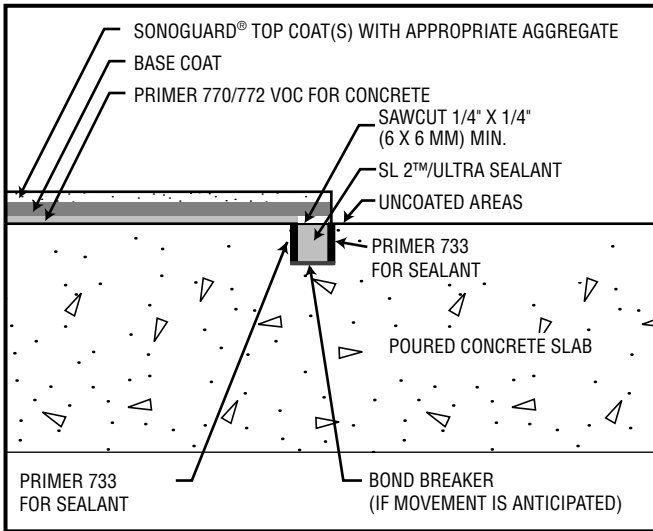

Key-Way or Termination Detail

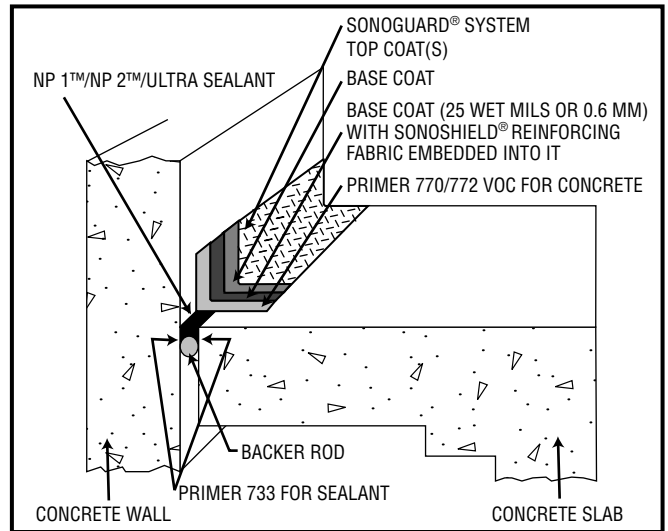

Joint at Wall/Slab

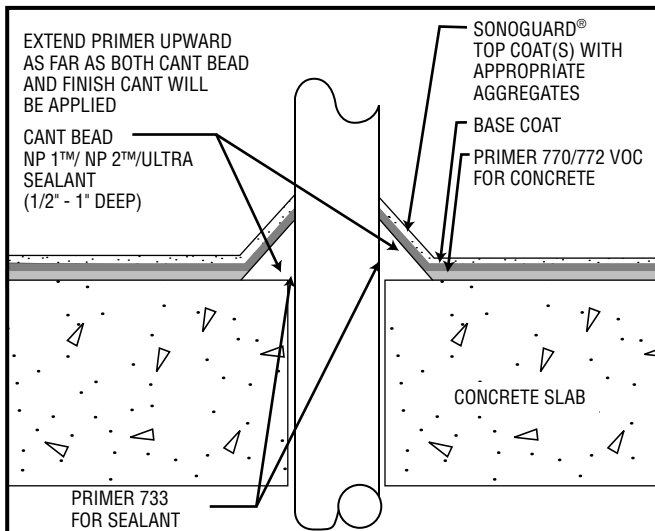

Penetration Detail

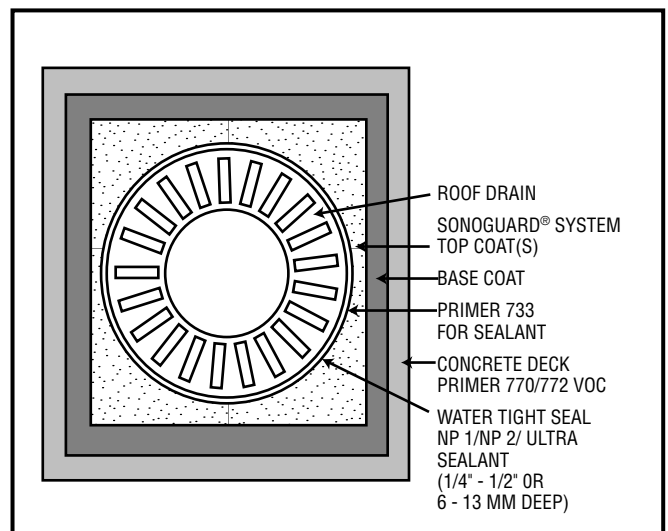

Roof Drain

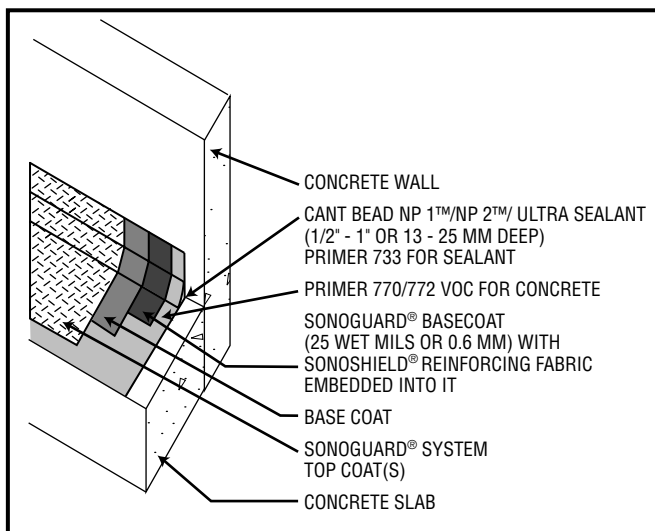

Slab Abutting Wall

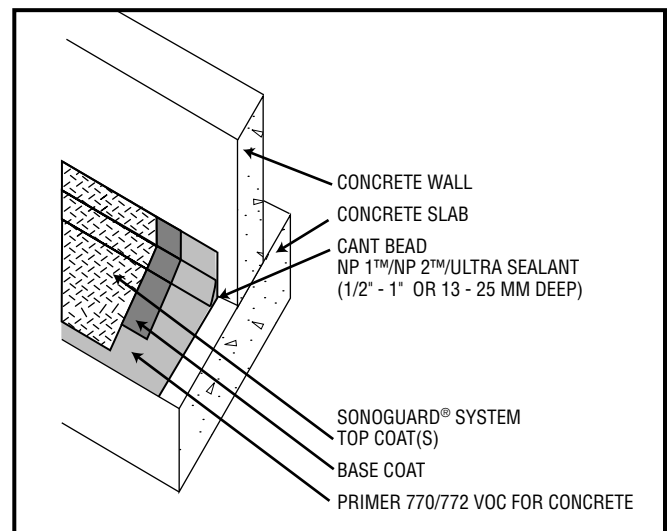

Wall Bearing on Slab

General design details. Specific installations may require designer modification.

Warning

Sonoguard® Base Coat contains titanium dioxide, talc, calcium carbonate, calcium sulfate, stoddard solvent, toluene diisocyanate, silicon dioxide.

Risks

Combustible liquid and vapor. Inhalation of vapors may cause irritation and intoxication with headaches, dizziness and nausea. May cause skin and eye irritation. Potential skin and/or respiratory sensitizer. Ingestion may cause irritation. Reports associate repeated or prolonged occupational overexposure to solvents with permanent brain, nervous system, liver and kidney damage. INTENTIONAL MISUSE BY DELIBERATELY INHALING THE CONTENTS MAY BE HARMFUL OR FATAL.

Precautions

KEEP OUT OF THE REACH OF CHILDREN. KEEP AWAY FROM HEAT, FLAME AND SOURCES OF IGNITION. Avoid contact with skin, eyes or clothing. Wash thoroughly after handling. DO NOT take internally. Use only with adequate ventilation. Use impervious gloves, eye protection and if the TLV is exceeded or used in a poorly ventilated area, use NIOSH/MSHA approved respiratory protection in accordance with applicable federal, state and local regulations. Keep container closed. All label warnings must be observed until container is commercially cleaned or reconditioned.

First Aid

In case of eye contact, flush thoroughly with water for at least 15 minutes. SEEK IMMEDIATE MEDICAL ATTENTION. In case of skin contact, wash affected areas with soap and water. If irritation persists, SEEK MEDICAL ATTENTION. Remove and wash contaminated clothing. If inhalation causes discomfort, remove to fresh air. If discomfort persists or any breathing difficulty occurs, or if swallowed, SEEK IMMEDIATE MEDICAL ATTENTION.

See Material Safety Data Sheet (MSDS) for further information.

Proposition 65

This product contains materials which are known to the state of California as known to cause cancer, birth defects, or other reproductive harm.

VOC Content

Self leveling grade: 196 g/L or 1.63 lbs. of VOC per gallon of coating less water and exempt solvents.

Flash/slope grade: 203.3 g/L or 1.7 lbs. of VOC per gallon of coating less water and exempt solvents.

Warning

Sonoguard® Top Coat contains mineral spirits, talc, calcium sulfate, methylene bis (4-cyclohexyl-isocyanate), may also contain titanium dioxide, and silicon dioxide.

Risks

Combustible liquid and vapor. May cause skin and eye irritation. May cause dermatitis and allergic responses. Potential skin and/or respiratory sensitizer. Inhalation of vapors may cause irritation and intoxication with headaches, dizziness and nausea. Ingestion may cause irritation. Reports associate repeated or prolonged occupational overexposure to solvents with permanent brain, nervous system, liver and kidney damage. INTENTIONAL MISUSE BY DELIBERATELY INHALING THE CONTENTS MAY BE HARMFUL OR FATAL.

Precautions

KEEP OUT OF THE REACH OF CHILDREN. KEEP AWAY FROM HEAT, FLAME AND SOURCES OF IGNITION. Keep container closed when not in use. Use only with adequate ventilation. Avoid contact with skin, eyes and clothing. Wash thoroughly after handling. Avoid breathing vapors. Use impervious gloves, eye protection and if the TLV is exceeded or if used in a poorly ventilated area, use NIOSH/MSHA approved respiratory protection in accordance with applicable federal, state and local regulations. Empty container

may contain explosive vapors or hazardous residues. Do not cut or weld on or near empty container. All label warnings must be observed until container is commercially cleaned or reconditioned.

First Aid

In case of eye contact, flush thoroughly with water for at least 15 minutes. SEEK IMMEDIATE MEDICAL ATTENTION. In case of skin contact, wash affected areas with soap and water. If irritation persists, SEEK MEDICAL ATTENTION. Remove and wash contaminated clothing. If inhalation causes discomfort, remove to fresh air. If discomfort persists or any breathing difficulty occurs, or if swallowed, SEEK IMMEDIATE MEDICAL ATTENTION.

See Material Safety Data Sheet (MSDS) for further information.

Proposition 65

This product contains material listed by the state of California as known to cause cancer, birth defects, or other reproductive harm.

VOC Content

209 g/L or 1.75 lbs. of VOC per gallon of coating less water and exempt solvents.

For medical emergencies only, call ChemTrec (1/800/424-9300)

Limited Warranty Notice

Every reasonable effort is made to apply ChemRex® exacting standards both in the manufacture of our products and in the information which we issue concerning these products and their use. We warrant our products to be of good quality and will replace or, at our election, refund the purchase price of any products proved defective. Satisfactory results depend not only upon quality products, but also upon many factors beyond our control. Therefore, except for such replacement or refund, CHEMREX® MAKES NO WARRANTY OR GUARANTEE, EXPRESS OR IMPLIED, INCLUDING WARRANTIES OF FITNESS FOR A PARTICULAR PURPOSE OR MERCHANTABILITY, RESPECTING ITS PRODUCTS, and CHEMREX® shall have no other liability with respect thereto. Any claim regarding product defect must be received in writing within one (1) year from the date of shipment. No claim will be considered without such written notice or after the specified time interval. User shall determine the suitability of the products for the intended use and assume all risks and liability in connection therewith. Any authorized change in the printed recommendations concerning the use of our products must bear the signature of the ChemRex® Technical Manager.



Sonneborn

ChemRex

Corporate Office:

889 Valley Park Drive, Shakopee, MN 55379

Customer Service: 1/800/433-9517

Technical Services: 1/800/ChemRex (1/800/243-6739)

Web Site: www.chemrex.com

